

## SPECIFICATIONS:

MODEL NUMBER: 2088-594-144

PUMP DESIGN: Positive Displacement 3 Chamber Diaphragm Pump

CHECK VALVE: (1-Way Operation) Prevents Reverse Flow

CAM: 3.0 Degree

MOTOR: Permanent Magnet, P/N 11-195-01, Thermally Protected

VOLTAGE: 115 VAC Nominal

PRESSURE SWITCH: Factory Set @ 45 PSI Shut-Off, Turn On 25 ±5 PSI

LIQUID TEMPERATURE: 130 Degrees Fahrenheit (54 Degrees Centigrade) Max.

PRIME: Self-Priming Up To 9.0 Ft. Vertical,  
Max. Inlet Pressure 30 PSI (2.1 Bar)

PORTS: 1/2" - 14 Male Parallel Thread

MATERIAL OF CONSTRUCTION:

PLASTICS- Polypropylene

VALVES- Santoprene

DIAPHRAGM- Santoprene

FASTENERS- Zinc Plated Steel

NET WEIGHT: 5.3 Lbs (2.4 Kg)

DUTY CYCLE: Intermittent (See Temp. Rise Chart)

TYPICAL APPLICATIONS: Agricultural Spraying

APPROVALS: UL Recognized Component

## DIMENSIONS:

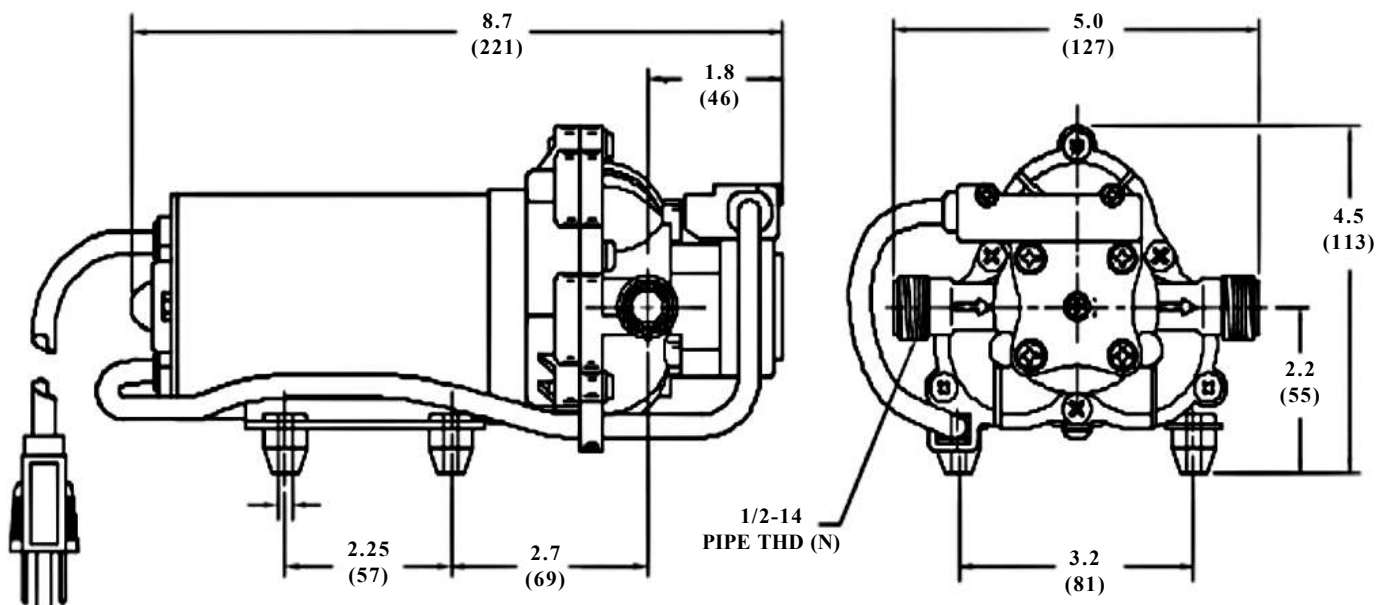

### TEMPERATURE RISE

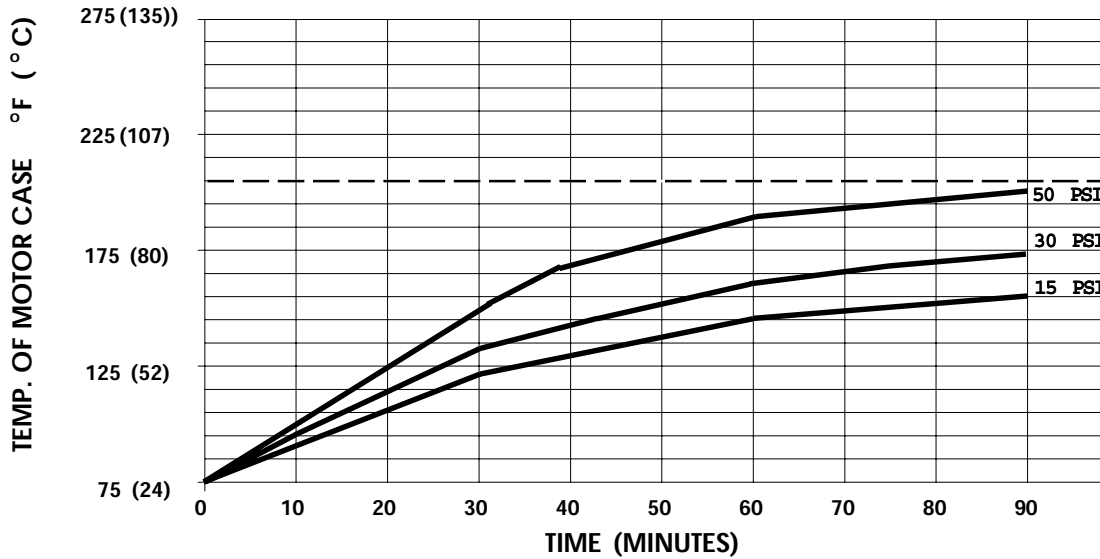

THIS GRAPH IS FOR USE AS A DESIGN GUIDE. IT IS BASED ON RUNNING CONTINUOUSLY WITH AN AMBIENT TEMPERATURE OF 75°F IN STILL AIR. THE THERMAL BREAKER WILL OPEN WHEN THE CASE TEMPERATURE REACHES 205° F.

[----- TRIP POINT OF THERMAL PROTECTOR]

### TYPICAL PERFORMANCE

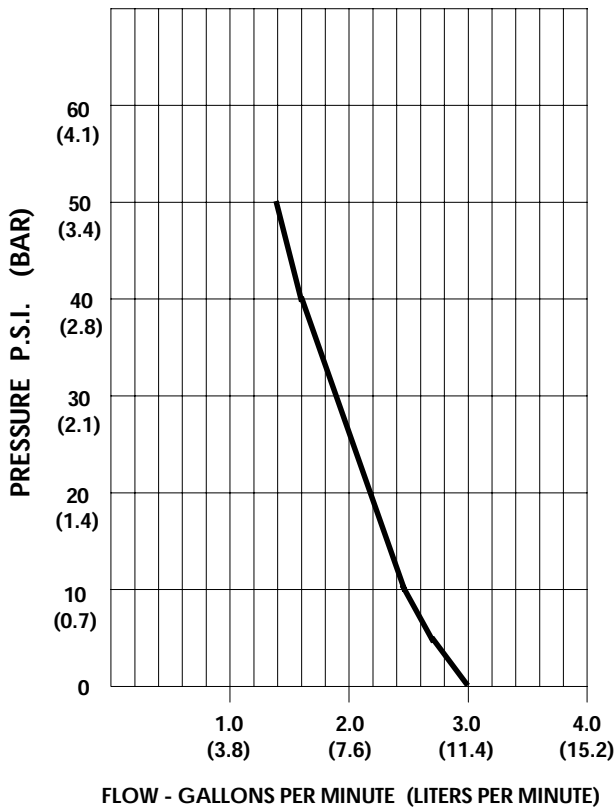

PRESSURE (PSI)	FLOW (GPM/LIT)	RPM MIN/MAX	CURRENT (AMPS)	VOLTAGE (VOLTS)
OPEN	3.0/11.3	1940/1945	0.50	115 V <sub>AC</sub>
10	2.4/9.1	1850/1850	0.55	"
20	2.2/8.3	1725/1725	0.60	"
30	1.9/7.2	1630/1630	0.65	"
40	1.6/6.0	1525/1530	0.70	"
50	1.4/5.3	1525/1530	0.75	"

-SPECIFICATIONS SUBJECT TO CHANGE WITHOUT NOTICE.  
 -ALL DATA BASED ON TESTING WITH WATER.